

TITLE				
Prototype This: Robo Dog Sitter				
DATE	FILENAME	SIZE	DRAWN BY	REV
10/26/2008	.	B	SHT 1 OF 1	Zoz

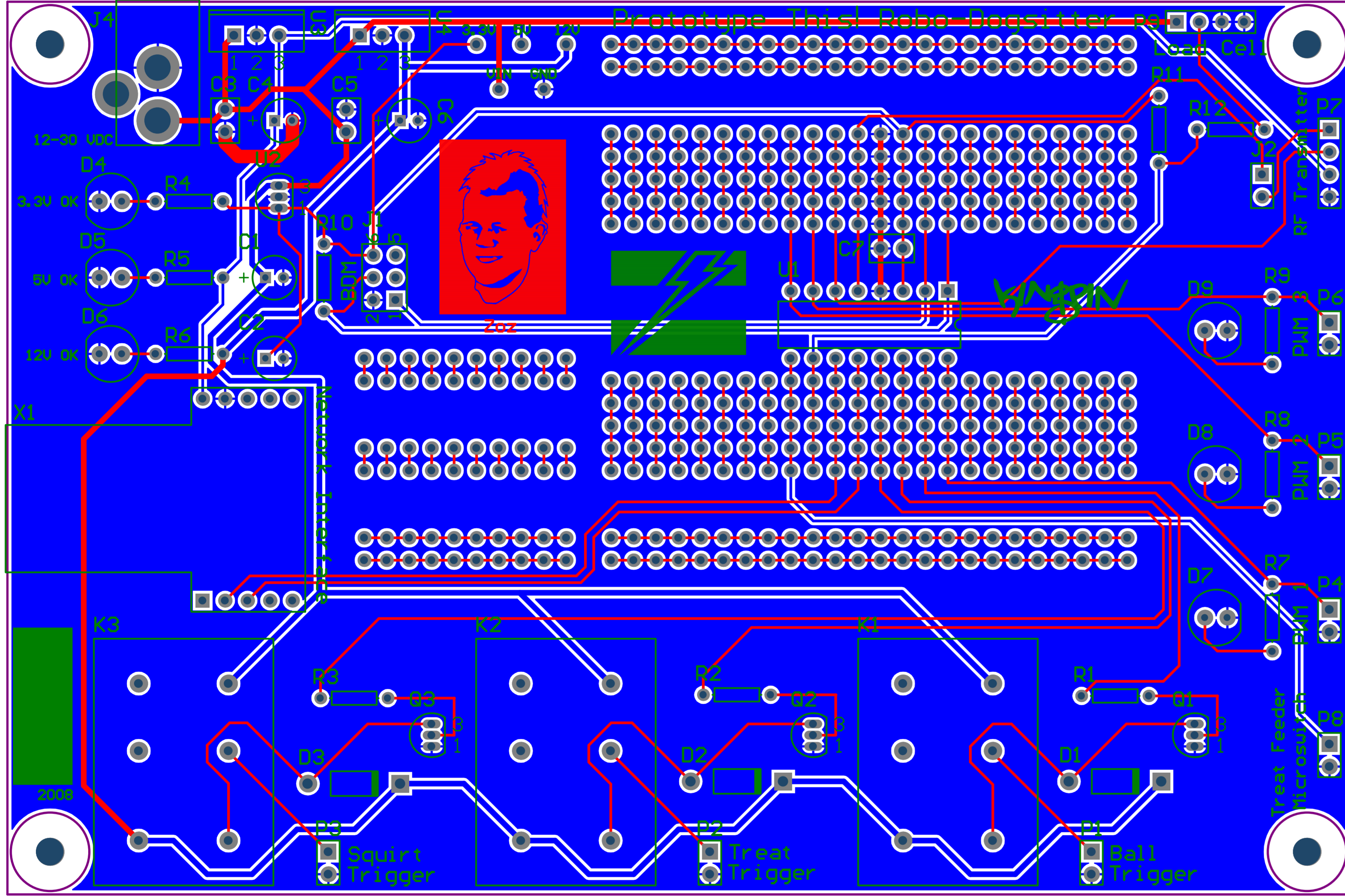

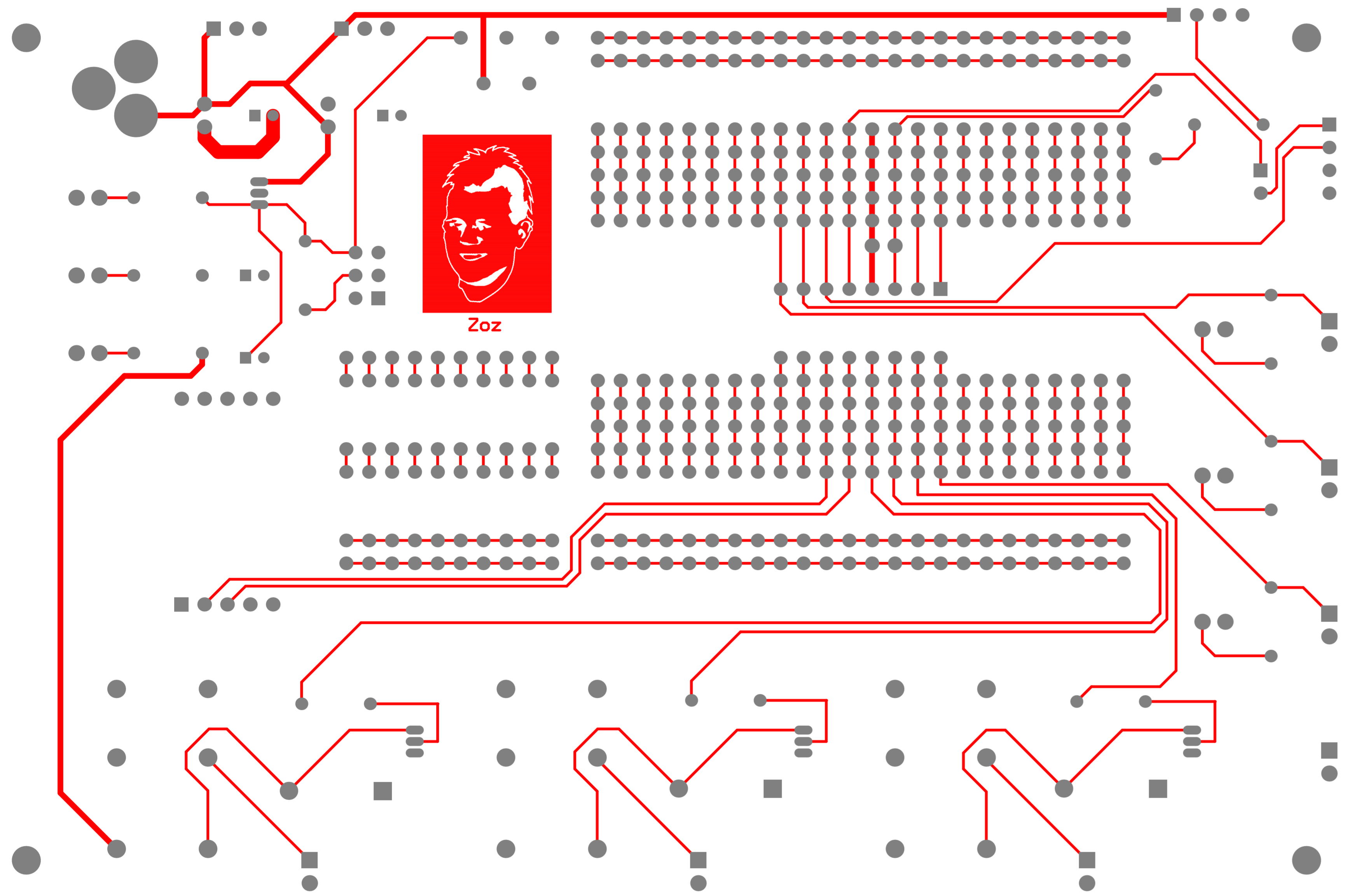

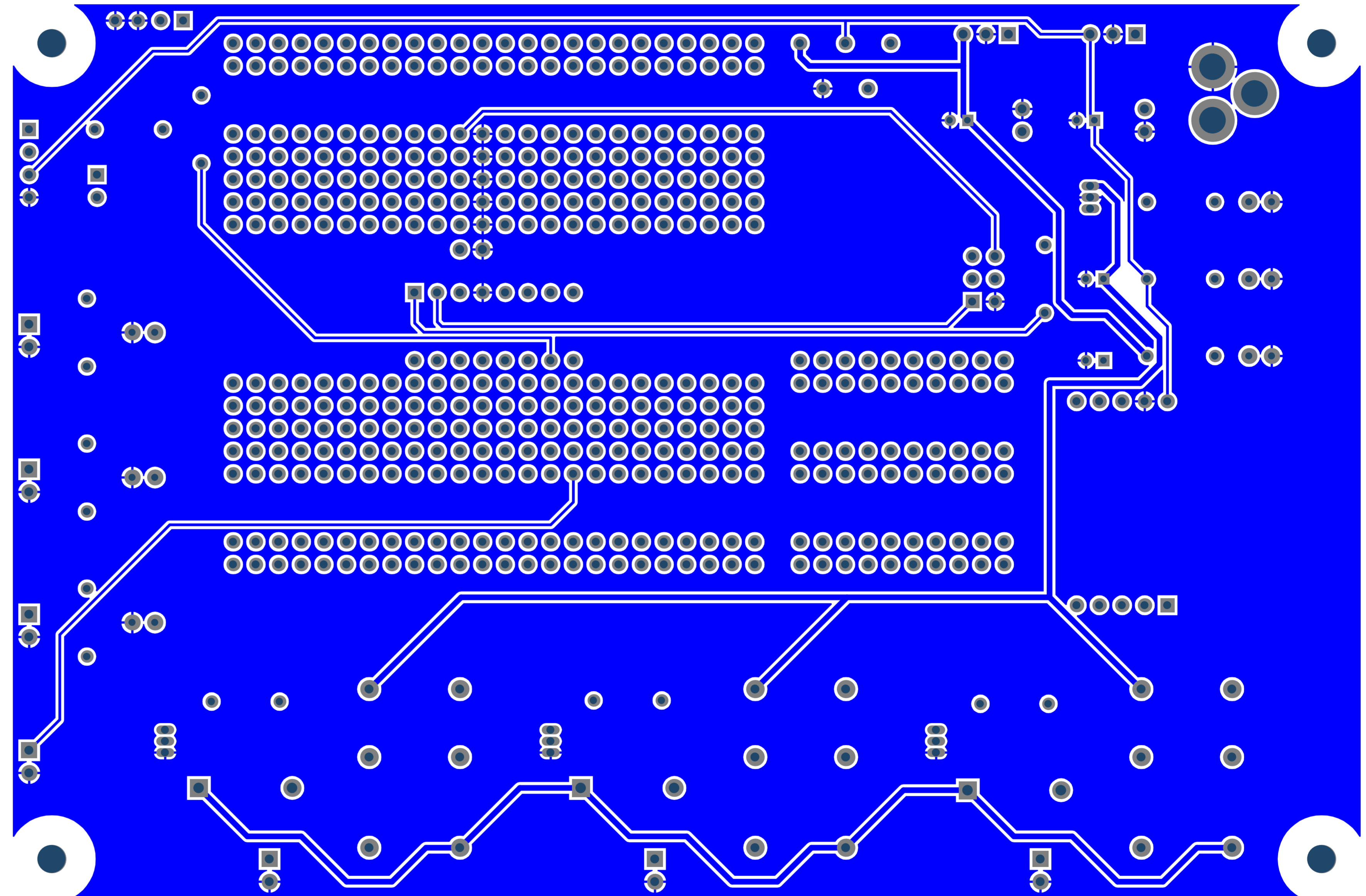



Prototype This! Robo-Dogsitter p9

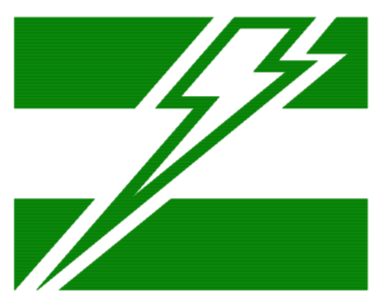
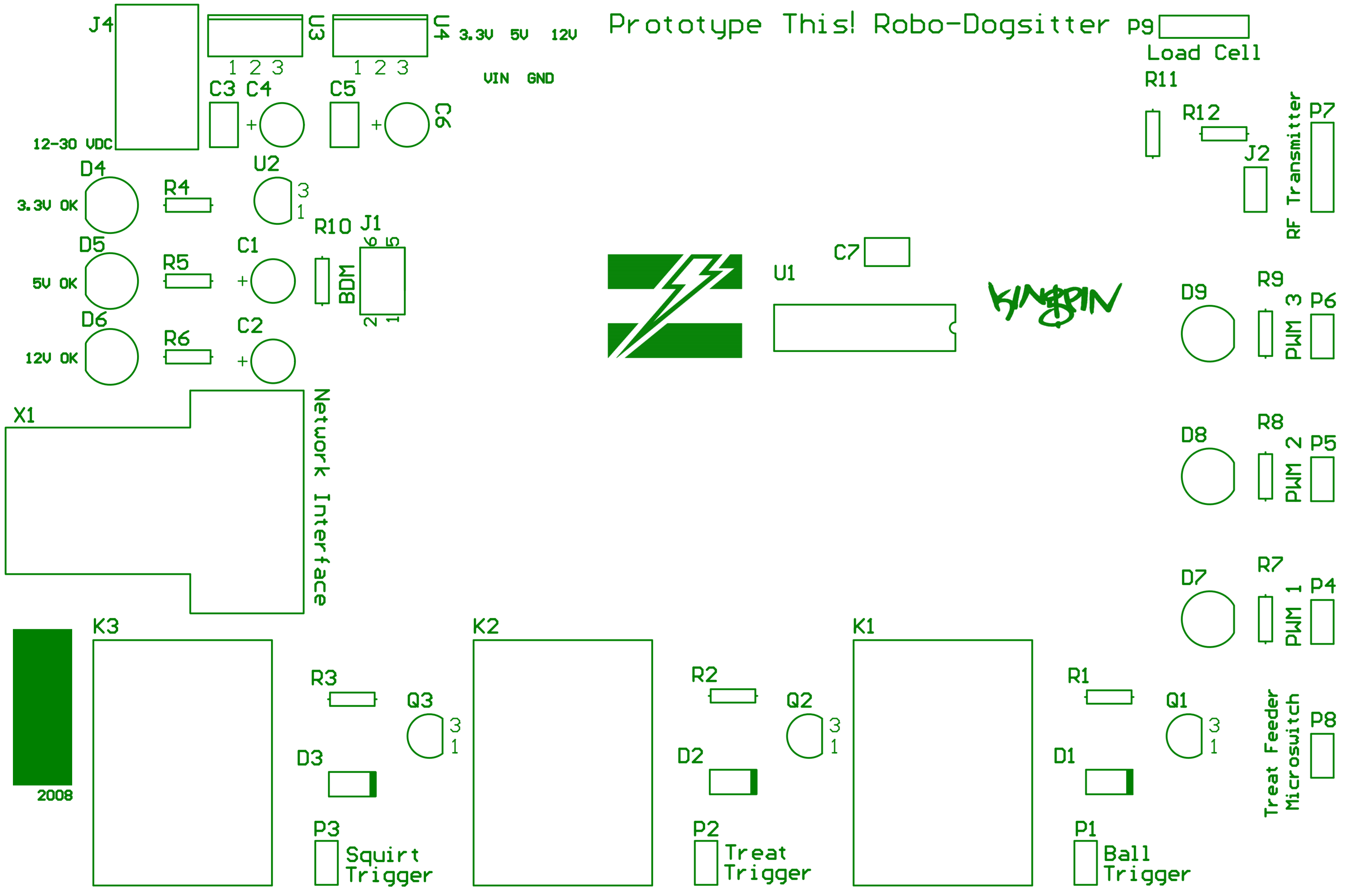

*KINGPIN*

2008

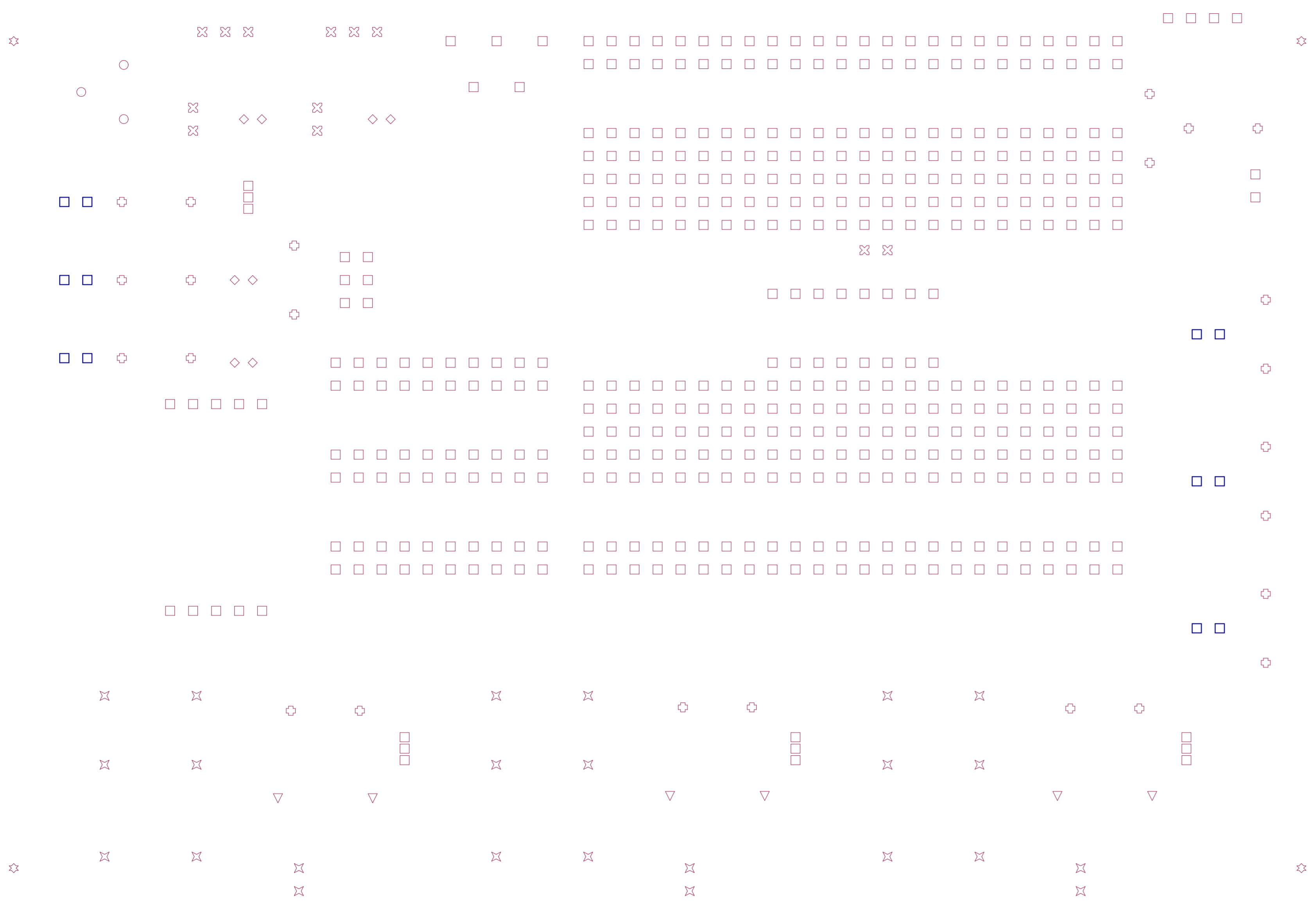

Symbol	Hit Count	Tool Size	Plated	Hole Type
◇	8	29.528mil (0.75mm)	PTH	Round
□	12	32mil (0.8128mm)	PTH	Round
⊕	24	33.465mil (0.85mm)	PTH	Round
□	455	35.433mil (0.9mm)	PTH	Round
⊗	12	39.37mil (1mm)	PTH	Round
⊗	32	40mil (1.016mm)	PTH	Round
▽	6	47.244mil (1.2mm)	PTH	Round
○	3	118.11mil (2.99999mm)	PTH	Round
⊗	4	125mil (3.175mm)	PTH	Round
	<b>556 Total</b>			

Drill Drawing.

